ALK1000P-50

Artic Cat 1000 Lift Kit



Parts Available For These Popular Brands and Others

POLARIS

can-am



Kawasaki



HIGHLIFTER



sales@highlifter.com



800-699-0947 | 8:00am - 6:00pm CST



780 Professional Drive North, Shreveport, LA 71105



www.highlifter.com

Read before Installation

This product is designed for use on ATVs and/or RUVs to increase ground clearance and fender clearance. Purchasers should be aware that use of this product may increase the frequency of required maintenance, part wear, and will raise the center of gravity on your ATV and/or RUV, increasing risk of roll-over, injury and death on all types of terrain. It is your responsibility to always inform other operators and passengers of this vehicle about the added risks.

High Lifter Products, products are designed to best fit users ATV/RUV under stock conditions. Adding, modifying, or fabricating any OEM or aftermarket parts will void warranty. High Lifter Products, products could interfere with other aftermarket accessories. If the user has aftermarket products on machine, contact High Lifter Products to verify that they will work together. Adding aftermarket suspension components and/or more aggressive tires can cause breakage of other OEM driveline components such as differentials, axles or drive shafts.

We recommend that wider tires and/or wheel spacers be used to achieve a wider stance and to improve stability of the ATV and/or RUV. Riders should be advised that the handling characteristics of a taller ATV and/or RUV are different and require extra care when riding, particularly on side hills or off-camber situations. If you further raise the center of gravity by adding taller tires, heavy loads to racks or seats, or by any other means, the ATV and/or RUV must be operated with even more care, at slower speeds and on relatively flat ground. All turns should be done at a slow speed, even on level ground.

Operation of an ATV and/or RUV with or without modified suspension components, while or shortly after consuming alcohol or drugs, subjects the rider to the risk of serious bodily harm or possible death. This risk is compounded if the rider does not wear an approved helmet and other safety gear. High Lifter urges that all approved safety gear be worn when riding an ATV and/or RUV as a driver or passenger.

By purchasing and installing High Lifter Products, products, user agrees that should damages occur, High Lifter Products will not be held responsible for loss of time, use, labor fees, replacement parts, or freight charges. High Lifter Products will not be held responsible for any direct, indirect, incidental, special, or consequential damages that result from any product purchased from High Lifter Products. The total liability of seller to user for all damages, losses, and causes of action, shall not exceed the total purchase price paid for the product that gives rise to the claim.

Dealers and other Installers

You are responsible for informing your customer and end user of the information contained above and the increased potential hazards of operating an ATV and/or RUV equipped with modified suspension components. If you install any suspension modifying components, it is your responsibility to also install the warning label prominently in view of the driver and in prominent view of the driver and passenger on RUVs and multi-passenger ATVs. They should also be instructed to notify anyone operating the vehicle, as well as any passengers, that said vehicle is modified.

As discussed above, it is critically important that they be instructed in the need for slower speed operation, regardless of terrain, after this lift kit is installed.

Parts Diagram

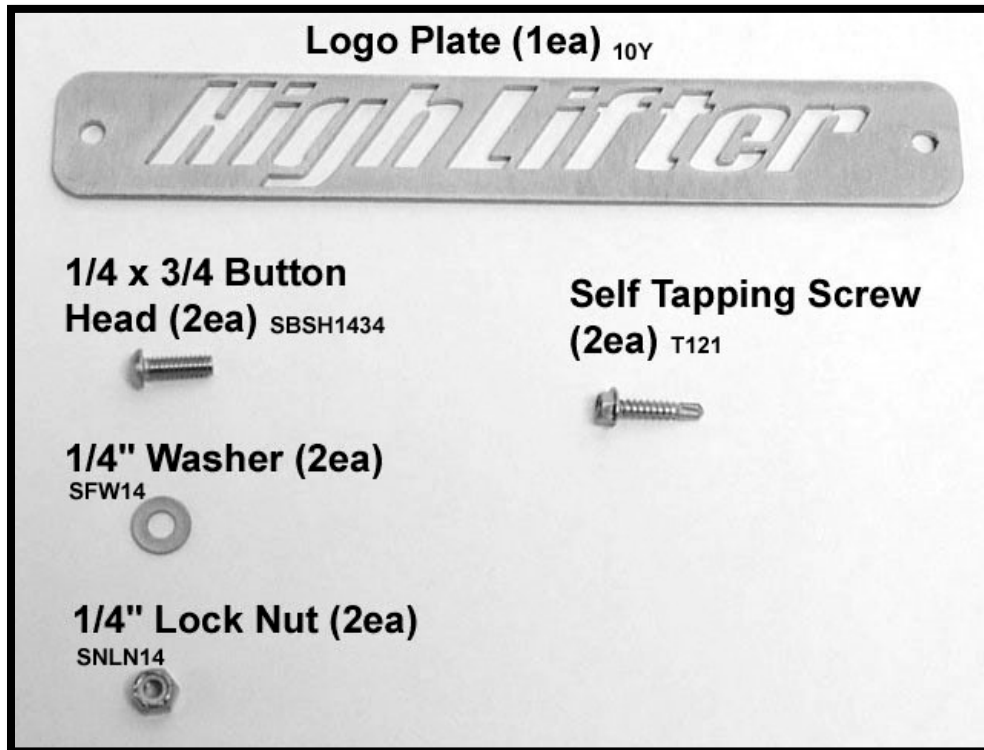
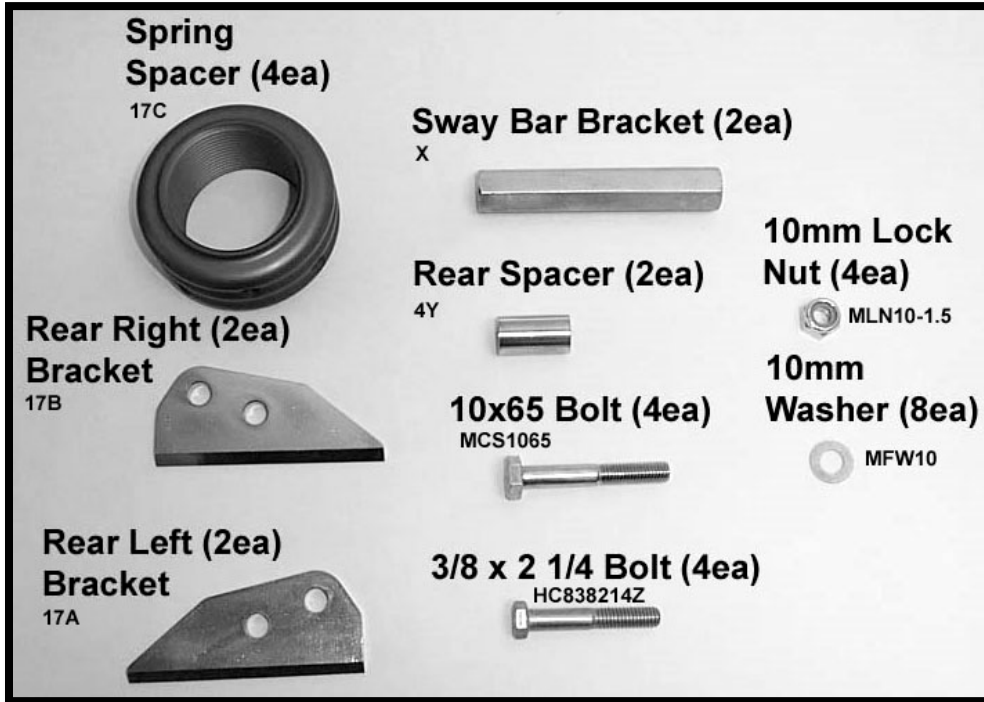

Front Lift Installation

- 1) Place UTV transmission in park. Place jack under center of UTV front end and lift until front wheels clear the ground. Be careful to support UTV properly so that it is securely supported so that A-arms and shocks can droop to full extension.
- 2) Remove front wheels.
- 3) Disconnect the front shocks from the UTV.

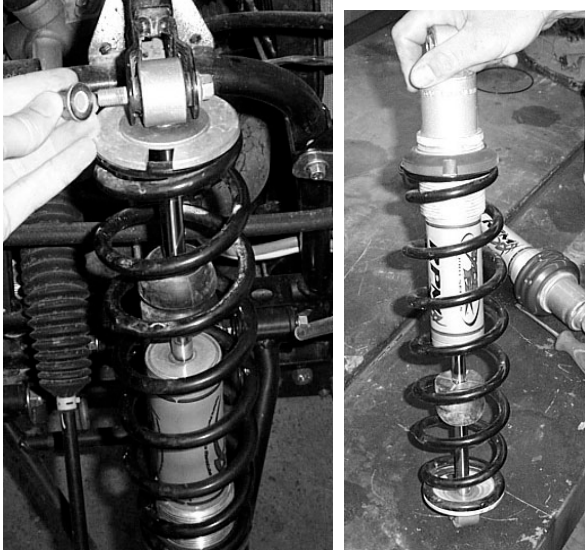

- 4) Disassemble the shock by turning the spring adjuster all the way down so that there is hardly any tension on the shock. Once you have done this remove the clip that holds the spring on place and remove the spring.

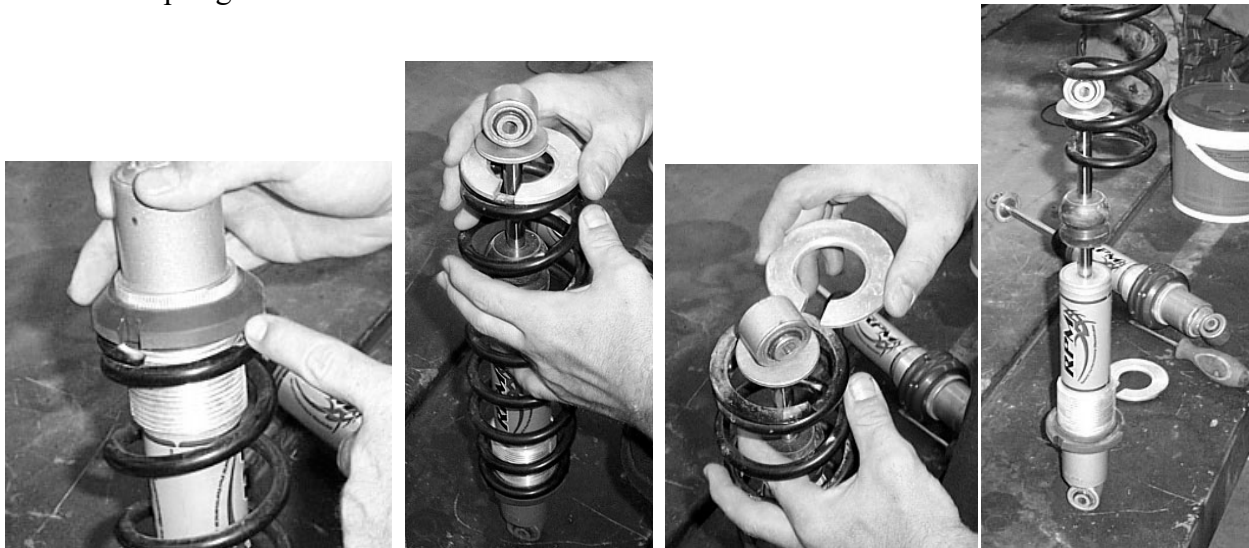

- 5) Remove the factory spring adjuster from the shock.



- 6) Insert the new spring adjuster onto the shock with the aligning facing up so that spring can nest onto the new adjuster.



- 7) Now place the spring back onto the shock. You will need a spring compressor at this point as the added height of the spring adjuster will make it difficult to install the retaining clip.



- 8) Compress the spring and insert the spring retaining clip.



- 9) Place the shock back on the UTV and adjust to desired height.
10) Place wheels back on UTV and torque all lugs to factory specifications.

NOTE: You will follow the same steps for the rear shocks.

Rear Lift Installation

- 1) Place UTV transmission in park. Place jack under center of UTV front end and lift until front wheels clear the ground. Be careful to support UTV properly so that it is securely supported so that A-arms and shocks can droop to full extension.
- 2) Remove rear wheels.
- 3) Follow the previous steps for installing the spring spacers.
- 4) Once you have installed the spring spacers onto the shocks attach the top of the shock to the UTV.
- 5) Next connect the lift brackets to the control arm.
- 6) Place one left lift bracket next to the shock mount and place one spacer into the shock mount tabs. Now insert a 10 x 65mm bolt to hold the bracket and spacer in place.

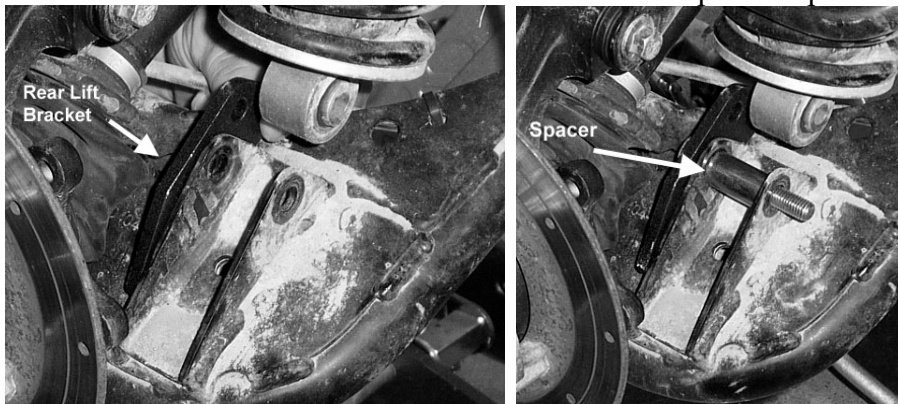

- 7) Insert another 10 x 65mm hex bolt through the top of the lift bracket and place two 10mm flat washers onto the bolt.

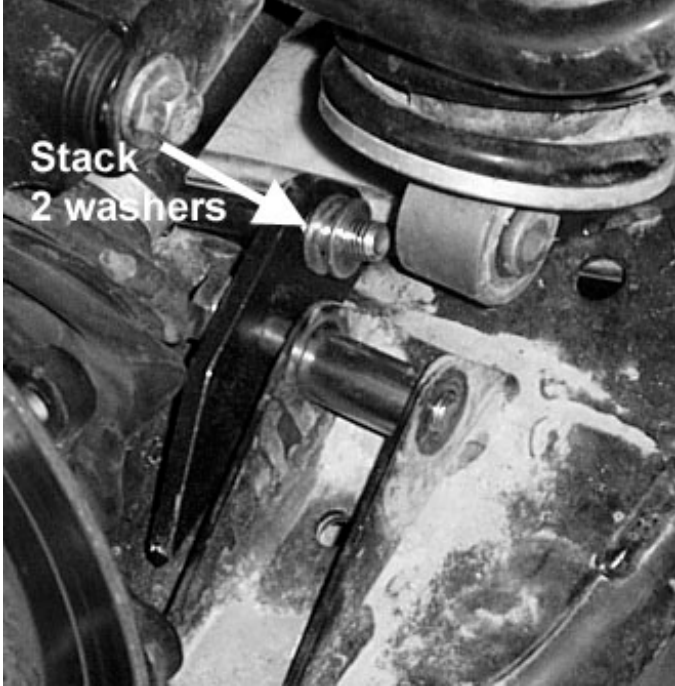

- 8) Insert the bolt through the shock and then stack two more washers on the bolt.



- 9) Place the one right lift bracket next to the shock mount and secure it using two 10mm lock nuts.



10) Now disconnect the rear stabilizer bar from the UTV.



11) Using the new stabilizer lift bracket and 3/8 x 2 1/2 hex bolts provided replace the stock stabilizer spacer with the new "Hex" style lift bracket.

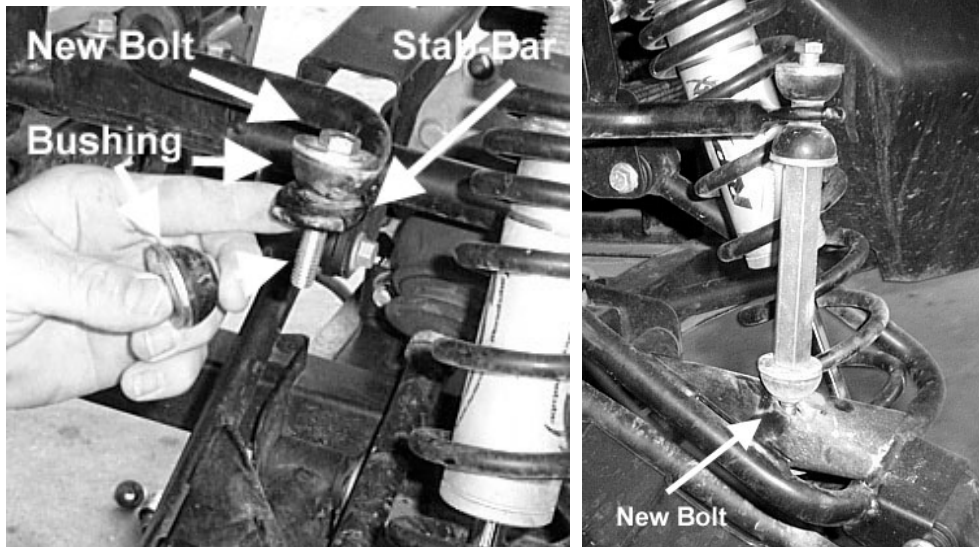

- 12) Repeat steps for opposite side.
- 13) Once you have added the spring stiffener, lift brackets, and stabilizer bar bracket place the wheels back on the UTV and torque lugs to factory specifications.

Logo Plate Installation

1. High Lifter provides two methods to secure the logo plate to the tail gate. We have in this kit self-tapping screws or 1/4" button head bolts.
2. If you choose to use the button head bolts, you will need to pull the tail gate off and disassemble it to attach the logo plate.
3. If you choose to use the self-tapping screws then all you need to do is place the logo plate in the center of the tail gate, drill a pilot hole, then attach with the self tapping screws.
4. The photos used in the illustration are using the self tapping screws.





High Lifter Lifetime Warranty

From the beginning, High Lifter has engineered and manufactured some of the toughest, most durable products on the market. That's why this product comes with a Lifetime Warranty. It's our promise that High Lifter will never let you down.

- The **Lifetime Warranty** covers products sold to the original purchaser only and is not transferable. The term of the warranty is for the lifetime of the vehicle in question.
- Normal wear and tear items and finishes, such as, but not limited to: Heim joints, tie rod ends, ball joints, bearings, seals, bushings, bushing sleeves, zinc plating , powder coating, or chipping and discoloration of any finish is not covered.
- High Lifter will ship the replacement product after the returned product has been inspected by High Lifter staff.
- The warranty shall not include claims for damages, installation time or labor charges, economic losses, inconvenience, transportation, towing, down time, direct or indirect or consequential damages or delay resulting from any defect.
- The warranty does not apply to products that have been improperly applied or improperly installed.

Making a warranty claim

1. All claims must be accompanied by the part and the original sales receipt or other acceptable proof of purchase from the original owner.
2. All warranties must be accompanied with a Return Merchandise Authorization (RMA) number. (Contact High Lifter at 318-524-2270 or 800-699-0947 for an RMA number)
3. When shipping the damaged product:
 - a. Write the RMA number on the outside of the box.
 - b. Also include the RMA number, proof of purchase and any notes inside the box.
 - c. Please keep your tracking number and shipment information.
4. The customer is responsible for shipping the product to High Lifter--return shipping within the lower 48 states will be paid by High Lifter products. With all warranty claims, only standard shipping services apply.
5. High Lifter will process your order within 24 business hours of receiving the returned item.
6. **Ship to:** High Lifter Products, 780 Professional Drive North, Shreveport, Louisiana 71105