



780 Professional Drive N. Shreveport, LA 71105 Phone (318)-524-2270 Fax (318)-524-2297  
www.highlifter.com

## **Honda Rincon Installation Instructions**

### Read before Installation

This product is designed for use on ATVs and/or RUVs to increase ground clearance and fender clearance. Purchasers should be aware that use of this product may increase the frequency of required maintenance, part wear, and will raise the center of gravity on your ATV and/or RUV, increasing risk of roll-over, injury and death on all types of terrain. It is your responsibility to always inform other operators and passengers of this vehicle about the added risks.

High Lifter Products, products are designed to best fit users ATV/RUV under stock conditions. Adding, modifying, or fabricating any OEM or aftermarket parts will void warranty. High Lifter Products, products could interfere with other aftermarket accessories. If the user has aftermarket products on machine, contact High Lifter Products to verify that they will work together. Adding aftermarket suspension components and/or more aggressive tires can cause breakage of other OEM driveline components such as differentials, axles or drive shafts.

We recommend that wider tires and/or wheel spacers be used to achieve a wider stance and to improve stability of the ATV and/or RUV. Riders should be advised that the handling characteristics of a taller ATV and/or RUV are different and require extra care when riding, particularly on side hills or off-camber situations. If you further raise the center of gravity by adding taller tires, heavy loads to racks or seats, or by any other means, the ATV and/or RUV must be operated with even more care, at slower speeds and on relatively flat ground. All turns should be done at a slow speed, even on level ground.

Operation of an ATV and/or RUV with or without modified suspension components, while or shortly after consuming alcohol or drugs, subjects the rider to the risk of serious bodily harm or possible death. This risk is compounded if the rider does not wear an approved helmet and other safety gear. High Lifter urges that all approved safety gear be worn when riding an ATV and/or RUV as a driver or passenger.

By purchasing and installing High Lifter Products, products, user agrees that should damages occur, High Lifter Products will not be held responsible for loss of time, use, labor fees, replacement parts, or freight charges. High Lifter Products will not be held responsible for any direct, indirect, incidental, special, or consequential damages that result from any product purchased from High Lifter Products. The total liability of seller to user for all damages, losses, and causes of action, shall not exceed the total purchase price paid for the product that gives rise to the claim.

### Dealers and other Installers

You are responsible for informing your customer and end user of the information contained above and the increased potential hazards of operating an ATV and/or RUV equipped with modified suspension components. If you install any suspension modifying components, it is your responsibility to also install the warning label prominently in view of the driver and in prominent view of the driver and passenger on RUVs and multi-passenger ATVs. They should also be instructed to notify anyone operating the vehicle, as well as any passengers, that said vehicle is modified.

As discussed above, it is critically important that they be instructed in the need for slower speed operation, regardless of terrain, after this lift kit is installed.

# Parts Diagram

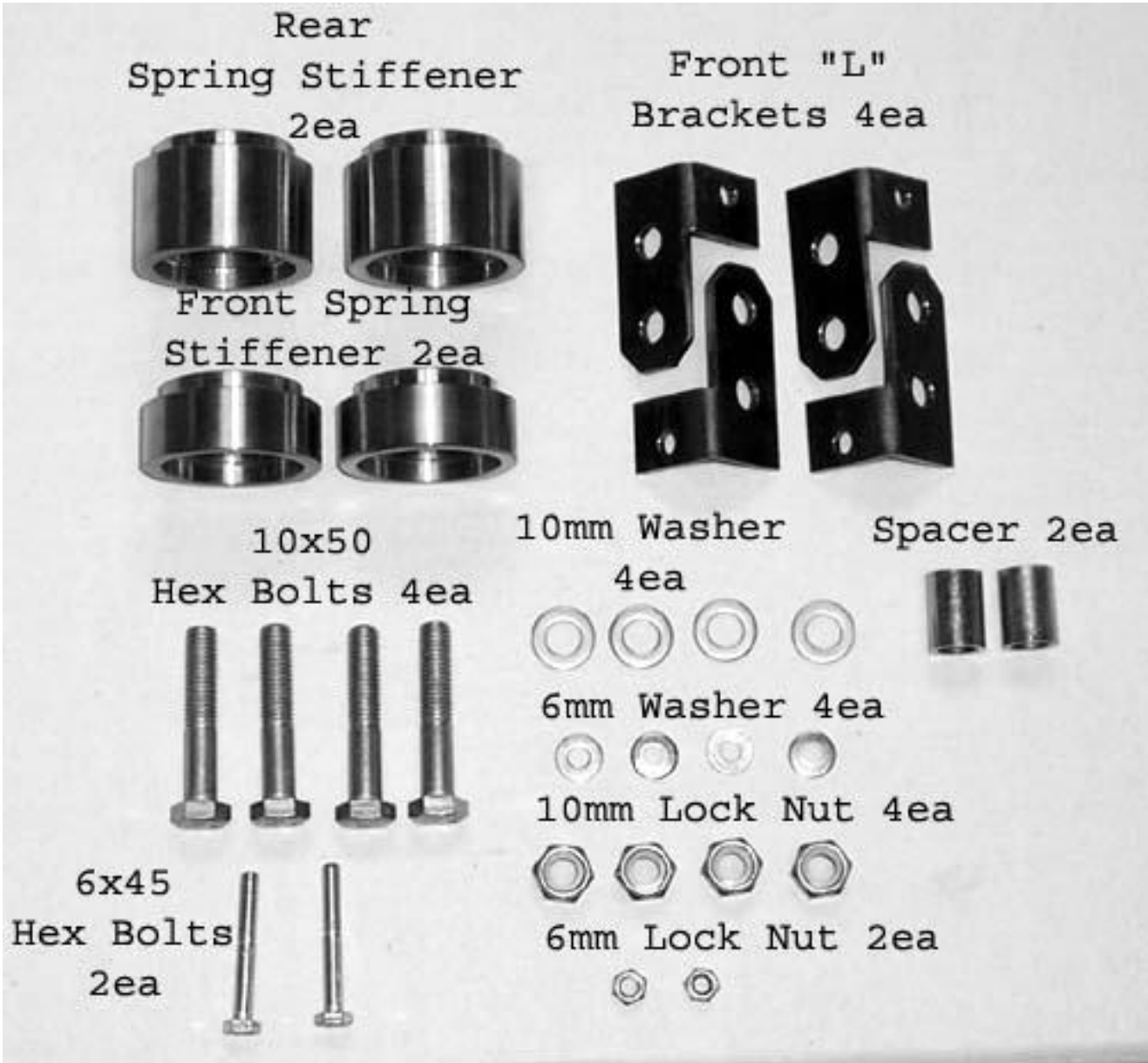

## Front Lift Installation

1. Place jack under center on the ATV front end and lift until front wheels clear the ground. Be careful to support ATV properly so that it is secure, but so that the A-arms and shocks can droop to full extension.
2. Remove front wheels and shocks.
3. Using a shock spring compressor, compress the spring on the shock and remove the spring retaining ring.

**CAUTION: The spring is installed under tension. Failure to use a shock spring compressor could cause loss of control of the spring, which could unload rapidly causing bodily injury. If you do not have a shock spring compressor you should acquire one or take it to a dealer or professional mechanic for installation of the stiffeners.**

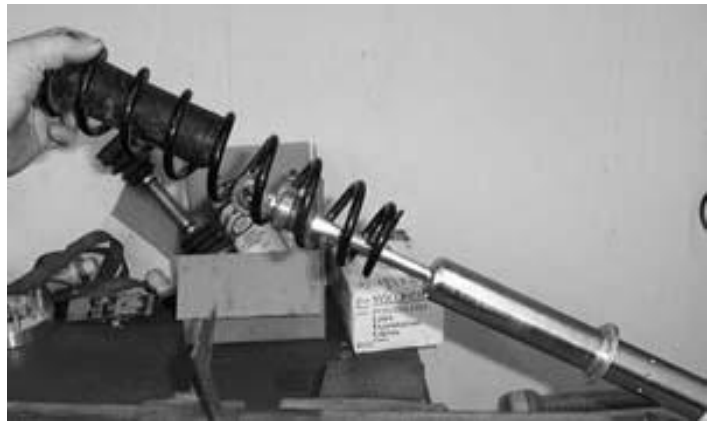

4. Remove the spring.
5. Insert the smaller front spring stiffener onto the shock with the lip of the spring stop, on the shock, mating into the recessed portion of the spring stiffener.
6. Slide the spring back onto the shock and it should rest on the lip of the spring stiffener.
7. Reattach the spring retaining ring.

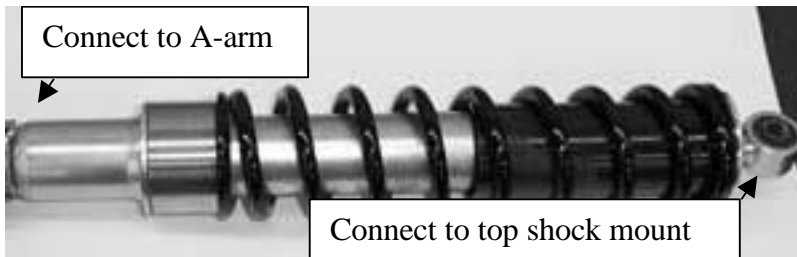

8. Repeat steps for the opposite side.

**Once springs are complete reattach the top of the shock to the top shock mount on the ATV and the spring stiffener will be closest to the A-arm.**

9. Take two of the “L” brackets and connect them to the bottom of the shock, the part that connects to the A-arms.
10. There is a top and bottom to the “L” bracket. See the diagram

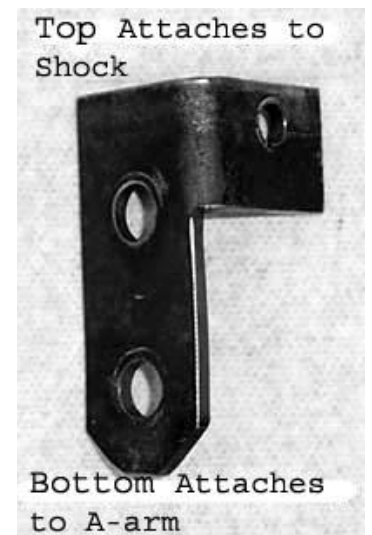

**Steps for installing the Front Lift “L” Brackets:**

1. Insert one 10x50 hex bolt into the “L” bracket and slide it into the shock through the spacer.

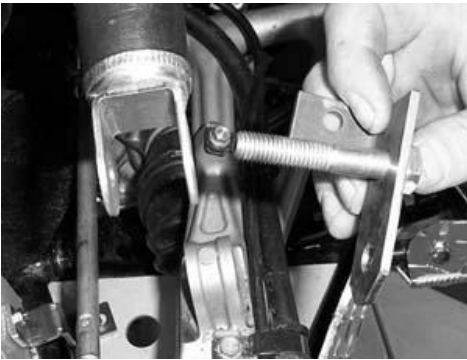

2. Connect the second “L” bracket to the other side and secure it with the 10mm Lock Nut.  
Note: Keep bolts loosely fasten, until the 6x45 hex bolt is inserted.

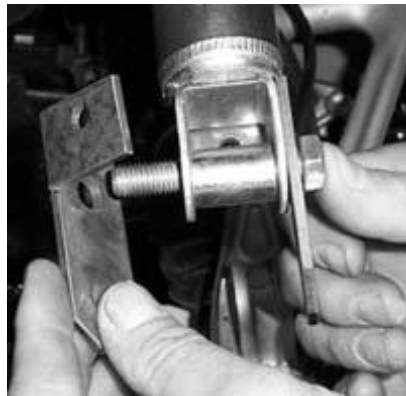

3. Insert the 6x45 hex bolt with the 6mm washer into the front of the brackets sliding in through above the spacer and securing it with the 6mm washer and lock nut on the backside.  
Note: Once the 6x45 hex bolt is installed fasten it tight, then fasten the 10x50 bolt tight.



- Secure the shock with the bracket attached to the shock mount on the A-arms with a 10x50 hex bolt. Place a 10mm flat washer between the bracket and shock mount. Fasten with the 10mm lock nut.

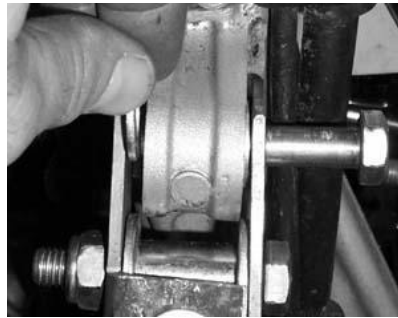

- Completed view of the shock mount bracket and the spring stiffener.



- Repeat steps for the opposite side.



## Rear Lift Installation

1. Place jack under the center ATV rear differential and lift until the weight is off the suspension. Be careful to secure ATV properly so as not to fall off the jack.

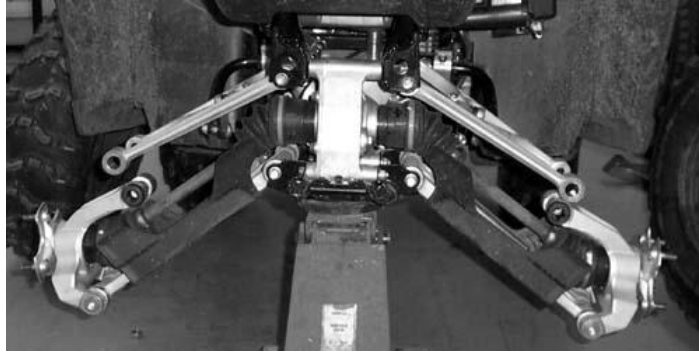

2. Remove the wheels and shocks.

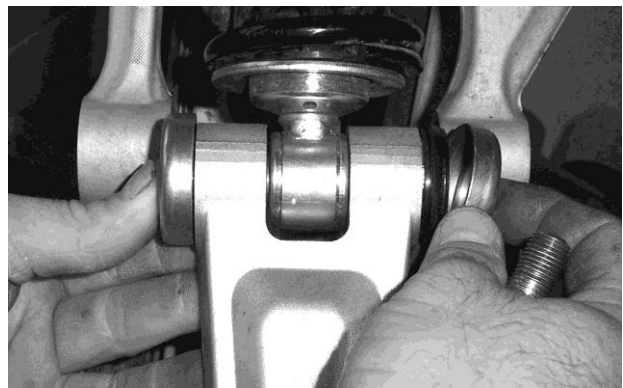

3. Using a shock spring compressor, compress the spring on the shock and remove the spring retaining ring.



4. Remove the spring.

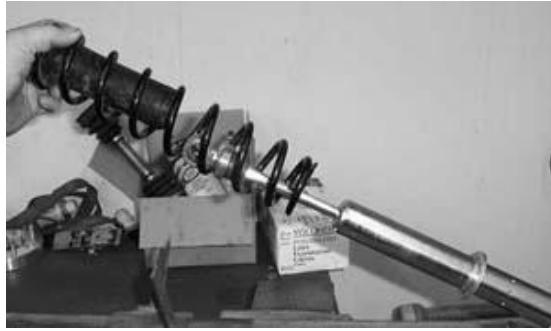

5. Insert the larger rear spring stiffener onto the shock with the lip of the of the spring stopper, on the shock, mating into the recessed portion of the spring stiffener.



6. Slide the spring back onto the shock and it should rest on the lip of the spring stiffener.



7. Reattach the spring retaining ring.
8. Reattach shock back to the ATV with the spring stiffener to the top nearest to the top shock mount.
9. Repeat steps for opposite side
10. Place wheels back on the ATV and lower jack.



Example of Spring Compressors:

High Lifter Product's Spring Compressor

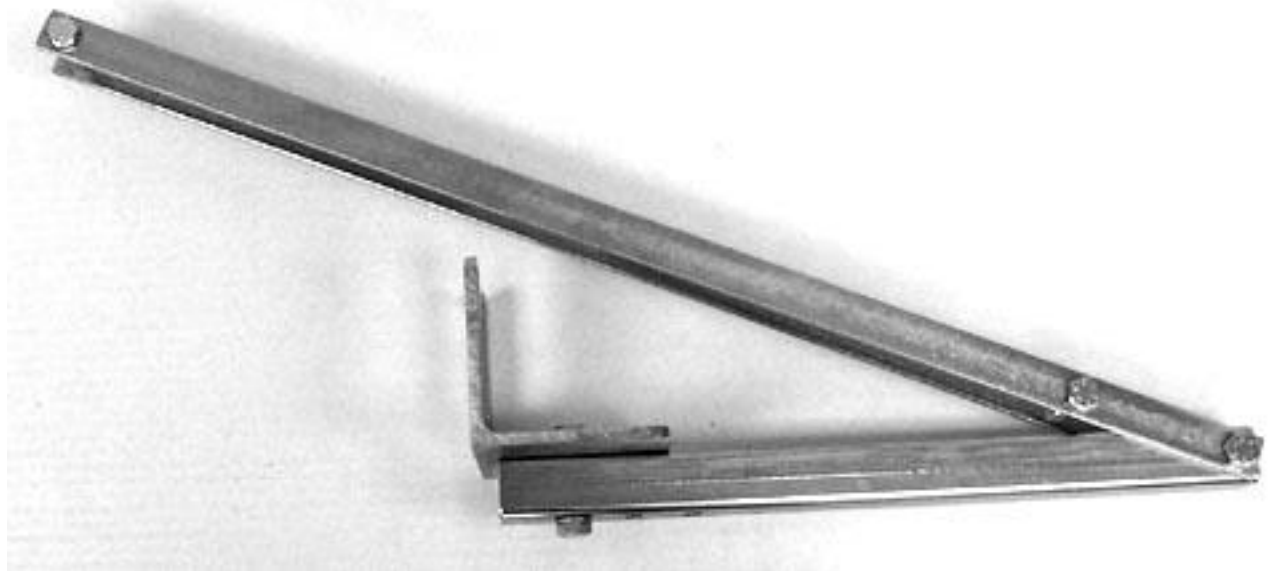

**Thank You**

**For choosing**







### **High Lifter Lifetime Warranty**

From the beginning, High Lifter has engineered and manufactured some of the toughest, most durable products on the market. That's why this product comes with a Lifetime Warranty. It's our promise that High Lifter will never let you down.

- The **Lifetime Warranty** covers products sold to the original purchaser only and is not transferable. The term of the warranty is for the lifetime of the vehicle in question.
- Normal wear and tear items and finishes, such as, but not limited to: Heim joints, tie rod ends, ball joints, bearings, seals, bushings, bushing sleeves, zinc plating , powder coating, or chipping and discoloration of any finish is not covered.
- High Lifter will ship the replacement product after the returned product has been inspected by High Lifter staff.
- The warranty shall not include claims for damages, installation time or labor charges, economic losses, inconvenience, transportation, towing, down time, direct or indirect or consequential damages or delay resulting from any defect.
- The warranty does not apply to products that have been improperly applied or improperly installed.

### **Making a warranty claim**

1. All claims must be accompanied by the part and the original sales receipt or other acceptable proof of purchase from the original owner.
2. All warranties must be accompanied with a Return Merchandise Authorization (RMA) number. (Contact High Lifter at 318-524-2270 or 800-699-0947 for an RMA number)
3. When shipping the damaged product:
  - a. Write the RMA number on the outside of the box.
  - b. Also include the RMA number, proof of purchase and any notes inside the box.
  - c. Please keep your tracking number and shipment information.
4. The customer is responsible for shipping the product to High Lifter--return shipping within the lower 48 states will be paid by High Lifter products. With all warranty claims, only standard shipping services apply.
5. High Lifter will process your order within 24 business hours of receiving the returned item.
6. **Ship to:** High Lifter Products, 780 Professional Drive North, Shreveport, Louisiana 71105